

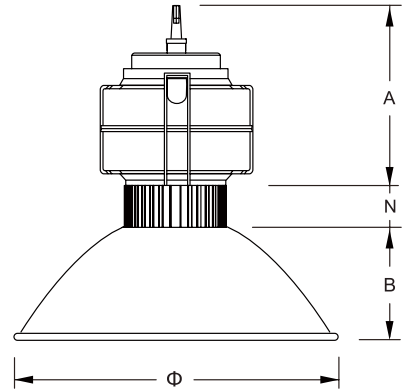

- High heat conductivity, low luminous decay, noiseless operation and no ghosting effect
- Multi-stage electronic dimming option available
- Electricity savings of 25-50% compared with high pressure sodium (HPS) lights and CFL light bulbs
- Multiple white colours available in the 2,700K-7,000K range
- Works across a wide input voltage range of 85V-265V
- Uses a single Bridgelux USA LED chip as the light source
- 35,000 hour lifetime achievable depending on room temperature
- IP65 certified to be dust proof and mist proof



Part No	LHB030200A-10	LHB040200A-10	LHB050200A-10	LHB060200A-10	LHB070200A-10	LHB100200A-10
Wattage (W)	30	40	50	60	70	100
Voltage Range (V)	AC 85-265 DC 12/24	AC 85-265 DC 12/24	AC 85-265 DC 12/24	AC 85-265 DC 12/24	AC 85-265 DC 12/24	AC 85-265 DC 12/24
Lumens (lm)	2400	3200	4000	4800	5600	8000
Luminous Efficiency (lm/W)	80	80	80	80	80	80
Color	WW/NW/CW	WW/NW/CW	WW/NW/CW	WW/NW/CW	WW/NW/CW	WW/NW/CW
Beam Angle (°)	60/90/120	60/90/120	60/90/120	60/90/120	60/90/120	60/90/120
Cover	Aluminium	Aluminium	Aluminium	Aluminium	Aluminium	Aluminium
LED Q'ty	1	1	1	1	1	1
Life Time (Hrs)	35000	35000	35000	35000	35000	35000
Dimensions (mm) A+B+N, Φ	175+100+N ø520/460/406	175+100+N ø520/460/406	280+178+N ø520/460/406	280+178+N ø520/460/406	280+178+N ø520/460/406	280+178+N ø520/460/406
Certificates	CE/RoHS	CE/RoHS	CE/RoHS	CE/RoHS	CE/RoHS	CE/RoHS

